

hear back PRO

16-CHANNEL PERSONAL MIXER SYSTEM

QUICK START GUIDE



SCAN
CODE
FOR USER
GUIDE

Thank you for purchasing the Hear Back PRO 16-channel personal monitor mixer system! Use this *Quick Start Guide* to setup quickly and easily. Refer to the *User Guide* for complete instructions, available online at www.hearback.com/support or scan the QR code above.

CONNECTING THE SYSTEM

- 1 Connect the appropriate input(s) as shown in the hook-up diagram.
- 2 Select the desired input using the front panel switch.
- 3 Connect Hear Back PRO Mixers to the Network Card outputs using CAT6* cables.
- 4 Turn on Hub Power.
- 5 Set all Mixer Channels and Master Volume levels to 0%.
- 6 Connect the headphones, in-ear monitors, and/or line outputs for connecting to wireless in-ear systems, powered monitors, or other devices requiring line-level inputs.

WARNING

- The Hear Back PRO is capable of driving most headphones to extreme levels that can damage your HEARING!
- ALWAYS turn down the Mixer "Master" volume down before putting on in-ear headsets or headphones.

HOOK-UP DIAGRAM

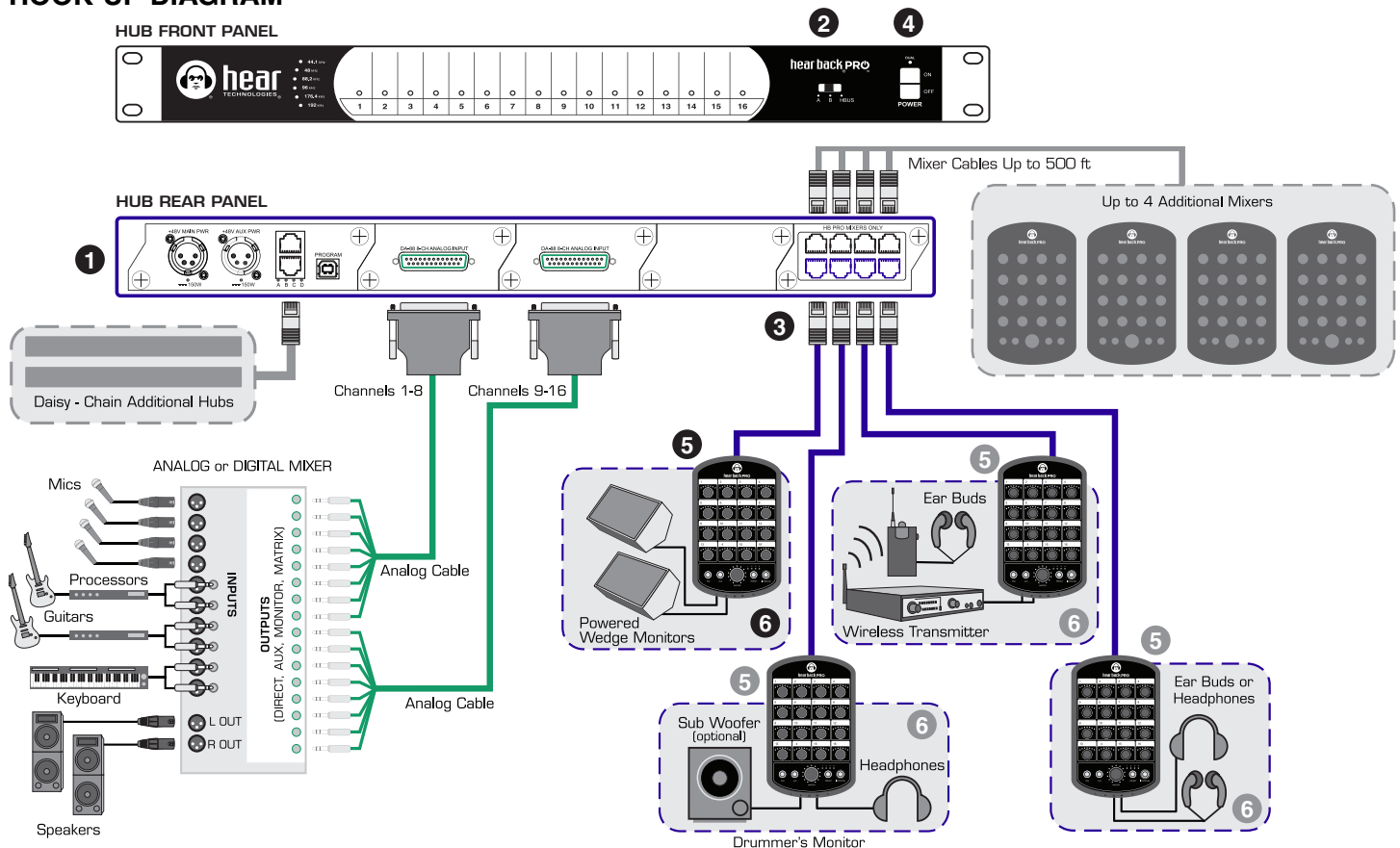

*Cable complying with the National authorities (cable with an outer jacket or sleeving rated VW-1 or better).



Hear Back PRO is proudly designed & assembled in the U.S.A. by musicians and audio engineers.



HUB DETAIL

- 1 - LED Status Indicator
- 2 - Sample Rate LED Indicators
- 3 - Audio Input Channels 1-16 Level LED Metering
- 4 - Input Selector Switch
- 5 - Power Switch
- 6 - Main 48V Power Input
- 7 - Secondary 48V Power Input
- 8 - HBus Input
- 9 - HBus Output
- 10 - USB Connection
- 11 - Card Slot 1 (shown with 8-channel Analog Input)
- 12 - Card Slot 2 (shown with 8-channel Analog Input)
- 13 - Card Slot 3 (shown unpopulated)
- 14 - Card Slot 4 (shown with 8-port Network Card)

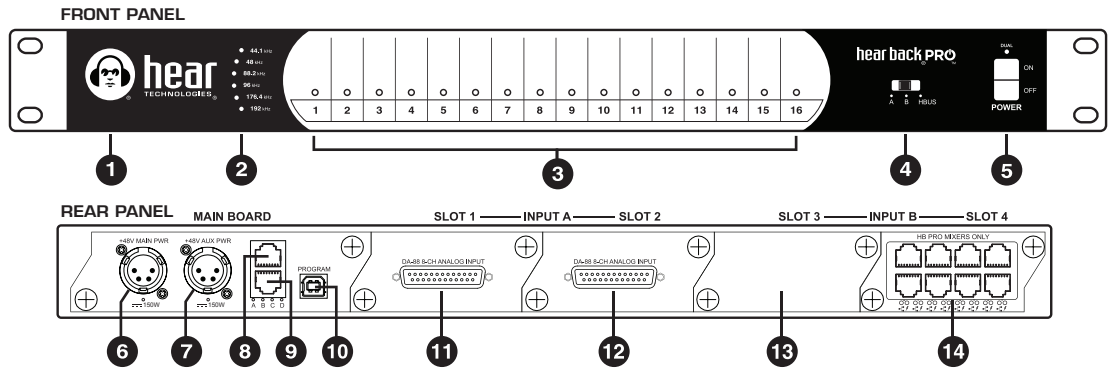

MIXER DETAIL

- 15 - LED Status Indicator
- 16 - LED Level Indicators
- 17 - Volume/Pan Control Knob for Each Audio Channel
- 18 - "Intercom" Button
- 19 - "Preset" Button
- 20 - "Master" Control Knob (Volume / Aux)
- 21 - "Aux" Input Button
- 22 - "Pan" Button
- 23 - Auxiliary 1/8" Stereo Unbalanced Audio Input
- 24 - Auxiliary Input Switch
- 25 - Auxiliary Balanced XLR Microphone Input with 15V Phantom Power
- 26 - 1/4" Balanced Left/Mono and Right Outputs
- 27 - 1/8" TRS Headphone Output
- 28 - 1/4" TRS Headphone Output
- 29 - Gigabit Ethernet (GbE) Connection with PoE+ (Power over Ethernet)

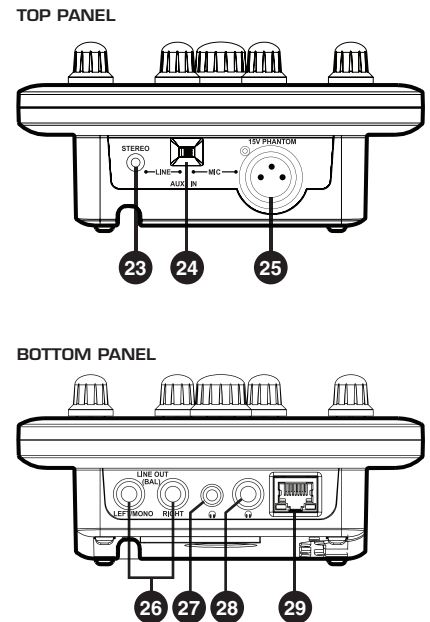
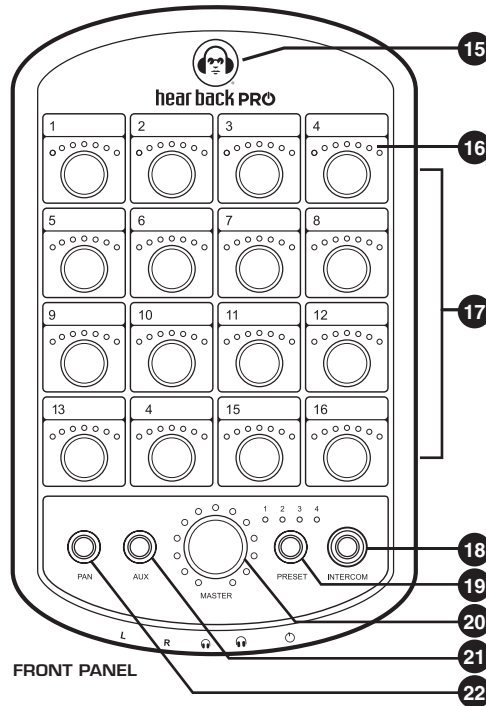

HUB ADJUSTMENT

- A. Adjust the level at the input source** (DAW, mixer, etc.) until the red clip LED's **3** on the Hub just come on.
- B. Reduce the levels on the input source until you have a "green" LED.**
- C. Adjust the source for as much signal into the Hub as possible without clipping.** Higher input levels improve signal-to-noise and dynamic range. If you are unable to adjust your source without overdriving the Hear Back PRO system, follow the "-10dB Pad" instructions below to achieve an extra 10db of headroom. Remember, higher input levels improve signal-to-noise and dynamic range.

-10dB PAD: The Analog input card provides 2 jumpers per channel (16 total) that can be removed to achieve a -10dB pad per channel. These jumpers are labeled 1-8 (corresponding to each input channel), and located one inch away from the DB-25 connector. So, in this example, input channels 1 & 4 will be reduced by 10dB, while input channels 2 & 3 are at 0dB:

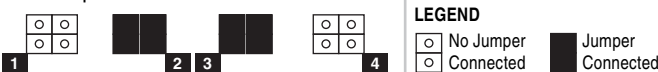

MIXER ADJUSTMENT

- A.** After you have the signals optimized on the Hub, turn the "Master" Volume **20** up to about 10 o'clock
- B.** Raise each channel's volume **17** to a comfortable level.
- C.** Avoid adjusting the master volume too high and running the inputs too low.
- D.** To stereo-link any channels, enter the stereo-link control interface as described in the User Guide, and toggle them on.
- E.** To Pan any mono channels within the stereo field, press the "PAN" button **22** to make adjustments.

AUX IN ADJUSTMENT

- F.** If using an auxiliary input, connect it to the Mixer via the appropriate "LINE" **23** or "MIC" **24** input.
- G.** Select the appropriate input via the "AUX IN" **25** switch.
- H.** If possible, adjust the input source for maximum volume without clipping.
- I.** Press the "AUX" button **21** to turn the "Master" knob LEDs "red" and slowly turn the "Master" knob **20** to a comfortable level.
- J.** Press the "AUX" button **21** again to exit auxiliary volume control.

